

3-WAY HEAVY DUTY FLOW CONTROL, WITH PRESSURE COMPENSATED AND SOLENOID CONTROLLED PRIORITY FLOW



A-VRFC3C-VEI-VS

0M.43.20.80 - Y - Z

Coil not included
ordered separately

Check valve to be ordered separately
"Option"

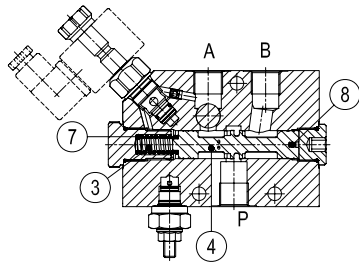
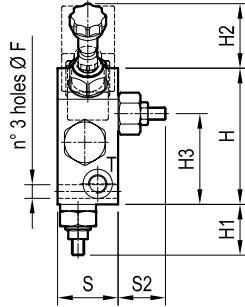
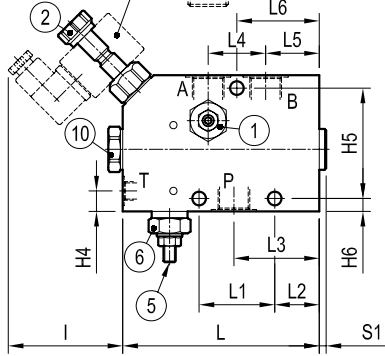

[mm (inches)]

Y=03-04

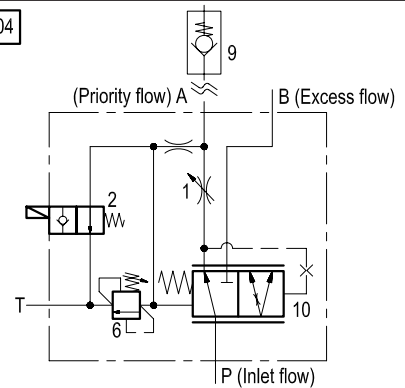

Y=05-06

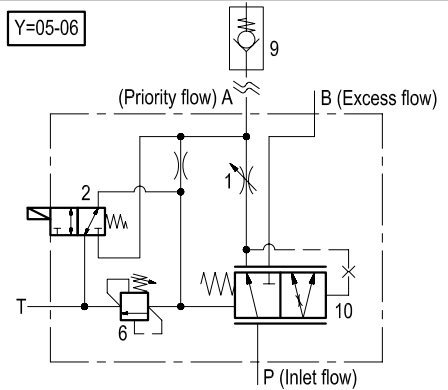

TECHNICAL DATA

Max operating pressure:	350 bar (5000 psi)
Max priority line pressure:	limited by relief valve (6) (see table "Z")
Back pressure at T port:	max 1.5 bar (20 psi)
Drain from T, with solenoid valve non-energized:	up to 1.5 l/min (up to 0.4 gpm)
Steel body	

32 (1.26)	5 (.2)	70 (2.76)	86 (3.39)	54.5 (2.15)	62.5 (2.46)	88.5 (3.48)	48 (1.89)	76 (2.99)	190 (7.48)	68 (2.68)	18 (.71)	90 (3.54)	14 (.55)	92 (3.62)	41 (1.61)	34 (1.34)	130 (5.12)	9 (.35)	G 1-1/4	12.5 (27.5)
32 (1.26)	5 (.2)	60 (2.36)	74.5 (2.93)	46.5 (1.83)	56.5 (2.22)	78 (3.07)	36.5 (1.44)	76 (2.99)	173 (6.81)	68 (2.68)	15 (.59)	90 (3.54)	13.5 (.53)	80.5 (3.17)	41 (1.61)	34 (1.34)	120 (4.72)	9 (.35)	G 1	9 (19.8)
32 (1.26)	5 (.2)	50 (1.97)	59 (2.32)	37 (1.46)	44 (1.73)	61 (2.4)	34 (1.34)	50 (1.97)	140 (5.51)	73 (2.87)	13.5 (.53)	73 (2.87)	13 (.51)	69.5 (2.74)	41 (1.61)	34 (1.34)	100 (3.94)	9 (.35)	G 3/4	4.8 (10.6)
32 (1.26)	5 (.2)	40 (1.58)	54.5 (2.15)	35.5 (1.4)	38 (1.5)	56.5 (2.22)	29.5 (1.16)	50 (1.97)	130 (5.12)	76 (2.99)	8.5 (.34)	73 (2.87)	12.5 (.49)	60 (2.36)	41 (1.61)	34 (1.34)	90 (3.54)	8.5 (.34)	G 1/2	3.4 (7.5)
S2	S1	S	L6	L5	L4	L3	L2	L1	L	I	H6	H5	H4	H3	H2	H1	H	F	Y	Weight kg (lbs)

Y	PORT SIZE		INLET FLOW (max)		REGULATED PRIORITY FLOW	
	P-A-B	T	l/min (gpm)	l/min (gpm) max	l/min (gpm) per turn	
03	G 1/2	G 1/4	100 (26)	85 (23)	approx. 18 (4.8)	
04	G 3/4	G 1/4	200 (53)	140 (37)	approx. 20 (5.3)	
05	G 1	G 1/4	300 (79)	220 (58)	approx. 26 (6.9)	
06	G 1-1/4	G 1/4	400 (106)	300 (80)	approx. 28 (7.4)	

Z	PRIORITY PRESSURE RANGE		
	Adj. press. range bar (psi)	Press. increase bar (psi) / turn	Std. setting bar (psi)
20	50-210 (725-3000)	48 (696)	200 (2900)
35	100-350 (1450-5000)	95 (1378)	350 (5000)

PERFORMANCE CURVES

PRIORITY FLOW vs PRESSURE

BY-PASS LINE PRESSURE DROP

Y = 03

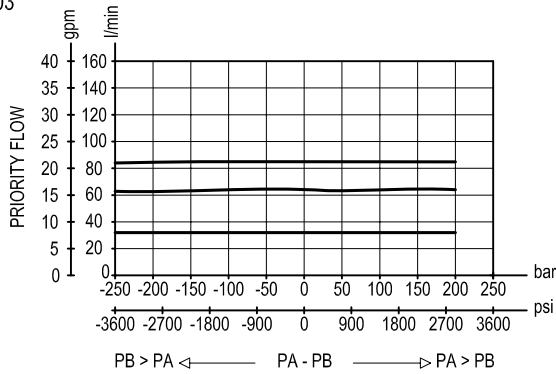

Y = 03

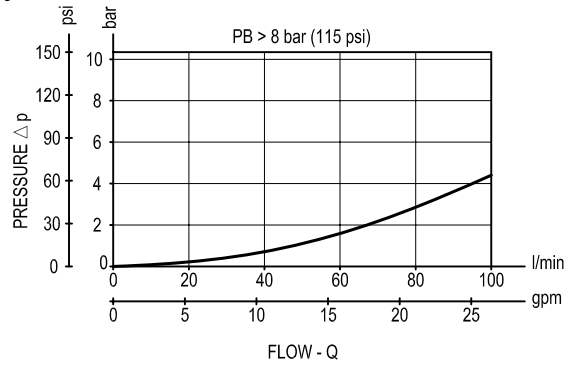

Y = 04

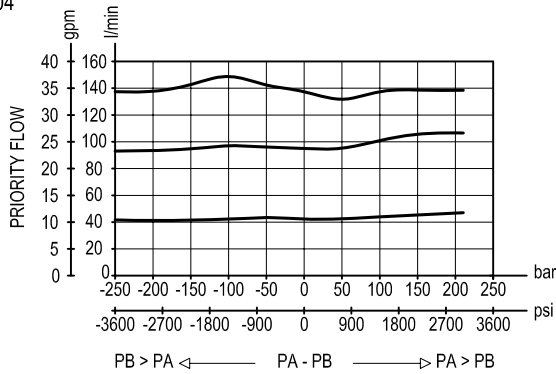

Y = 04

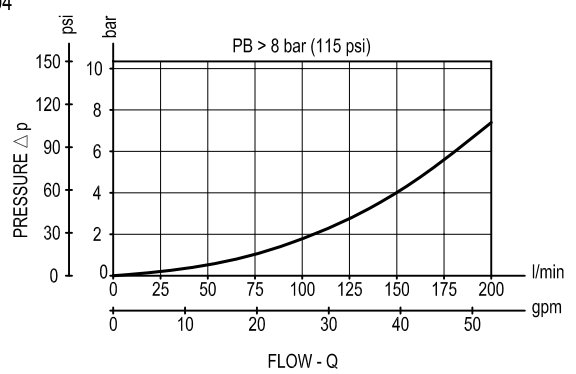

Y = 05

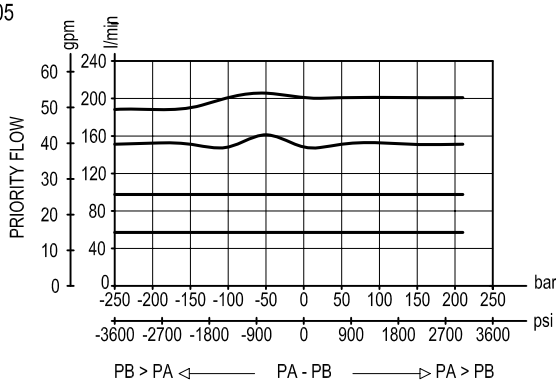

Y = 05

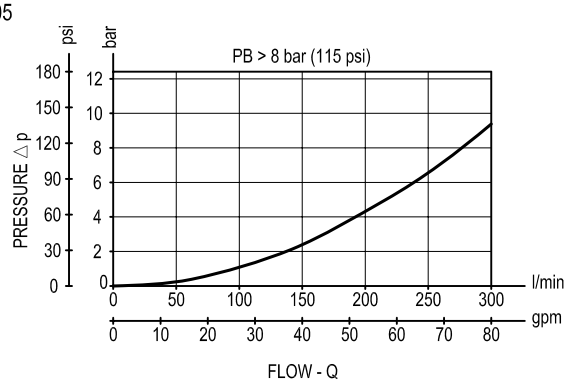

Y = 06

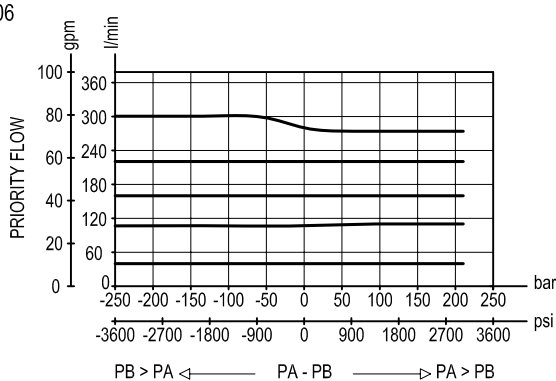

Y = 06

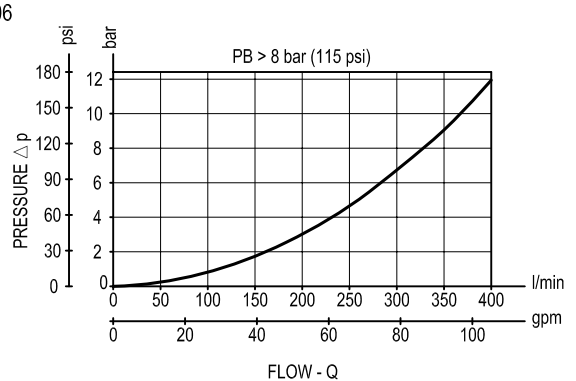

3-WAY HEAVY DUTY FLOW CONTROL, WITH PRESSURE COMPENSATED AND SOLENOID CONTROLLED PRIORITY FLOW

A-VRFC3C-VEI-VS

0M.43.20.80

The **FLOW CONTROL VALVES** series “**A-VRFC3C-VEI-VS**” are 3 way, with **one inlet “P” and two outlets “A” and “B”**, the first outlet “**A**” being **priority, pressure compensated type**, with pressure relief valve and available on demand through a solenoid cartridge; the second outlet “**B**” is the **by-pass** for all flow in excess of what demanded by priority. Both flows from “**A**” and “**B**” ports can be employed to power different functions of the machine.

These valves provide a simple and efficient way to power hydraulic tools (such as hydraulic hammers) from the existing hydraulic system, without any need to modify the directional control valve.

Applications

They allow the simultaneous operations, independently from the respective working pressures, of both the hydraulic actuator powered by the priority outlet “**A**”, and of the normal functions of the machine (traction, slewing, cylinder motions, etc.) supplied by the main directional valve through the by-pass outlet “**B**”.

FITTING AND CONNECTIONS

When positioning and tightening the valve, avoid any deflection of the body which could prevent the internal spool from sliding freely and impair the metering performance; it is recommended to use the 3 available fixation holes as locating points and to fit 3 equal spacers (metal washers), one on each point, between the valve body and the supporting structure.

Connections to the hydraulic system:

- Port “**P**” (inlet) to the main line from the pump.
- Port “**A**” (priority outlet) to the line feeding the hydraulic hammer, or the attachment. **Important:** for the correct metering of the compensating spool the priority outlet shall be always pressurized, **with a back-pressure of at least 8-9 bar (115-130 psi); if necessary, fit a check valve with the needed cracking pressure.**
- Port “**B**” (by-pass, or excess flow outlet) to the line delivering the oil to the main directional valve.
- Port “**T**” to a tank line. **It is absolutely necessary that port “T” is connected to a low pressure tank line, 1-1.5 bar max (15-22 psi max).**

SLEEVE TYPE CHECK VALVES

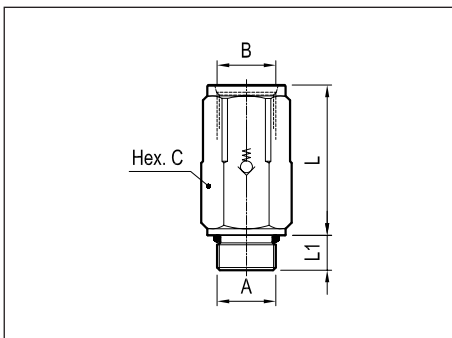

Port size A - B	Cracking Pressure bar (psi)	Dimension mm (inches)			Ordering code
		C	L	L1	
G 1/2	8 (115)	30 (1.18)	57 (2.24)	14 (0.55)	04.31.17.00.03.01.000
G 3/4	8 (115)	36 (1.42)	69 (2.72)	16 (0.63)	04.31.17.00.04.01.000
G 1	8 (115)	46 (1.81)	82 (3.23)	18 (0.71)	04.31.17.00.05.01.000
G 1 1/4	8 (115)	55 (2.17)	102 (4.02)	20 (0.79)	04.31.17.00.06.01.000

Adjustment of priority flow

The volume of priority flow from port “**A**” can be easily modified by turning the screw (1): the flow increases by turning the screw counter-clockwise and, once adjusted to the desired level, it remains constant independently from the working pressure.

Adjustment of maximum priority pressure

The maximum pressure in the priority line “**A**” can be adjusted by turning the screw (5) of the small relief cartridge (6) which controls the maximum pressure in the chamber (3): when this “pilot” cartridge opens, the pressure in chamber (3) drops and the priority flow is stopped.

Note: the relief cartridge (6) controls only the maximum pressure in the priority outlet “**A**”, **and does not control the pressure in the by-pass and main line: the main line must be protected by another relief valve, capable to discharge the full oil flow.**

**3-WAY HEAVY DUTY FLOW CONTROL,
WITH PRESSURE COMPENSATED AND
SOLENOID CONTROLLED PRIORITY FLOW**

A-VRFC3C-VEI-VS

0M.43.20.80

Ordering code: **OD.02.17 - X - Y - Z**

COILS

Attention: indicated coils fit every hammer valve versions

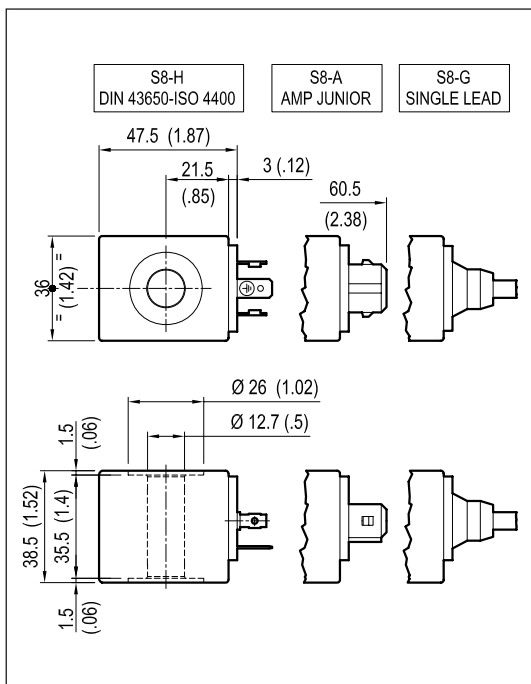

TECHNICAL DATA

Weight: 0.180 kg (0.4 lbs)
Encapsulating material: IXEF
Heat insulation Class H: 180°C (356°F)
Ambient temperature range: -30/+60°C (-86/+140°F)
Inlet voltage fluctuations must not exceed ±10% of nominal voltage to obtain correct operation and long life coils.

X	Y	Connections	Circuit	Voltage
01	30	DIN 43650 - ISO 4400	Standard	DC-RAC
07	30	AMP JUNIOR	Standard	DC only
0G	03	SINGLE LEAD	Standard	DC only *
14	30	DIN 43650 - ISO 4400	Bidirectional Diode	DC only
15	30	AMP JUNIOR	Bidirectional Diode	DC only
0H	03	SINGLE LEAD	Bidirectional Diode	DC only *

* Length 300mm (11.8 inches). Ext. diameter 6.3mm (0.25 inches). External and internal Sheath Silicone rubber.

Z	Voltage V	Resistance Ohm (±7%)	Power W	Current A		T °C (°F)
	Nominal	Ta = 20-25°C (68-77°F)	Cold coil	Cold coil	Hot coil	1 hour energized at Ta=20-25°C (68-77°F) Nominal voltage
OB	12 DC	7.4	20	1.62	1.19	105-110 (221-230)
OC	24 DC	28.5	20	0.85	0.61	
OG	14 DC		20			
AC	26 DC	34.3	20	0.76	0.54	

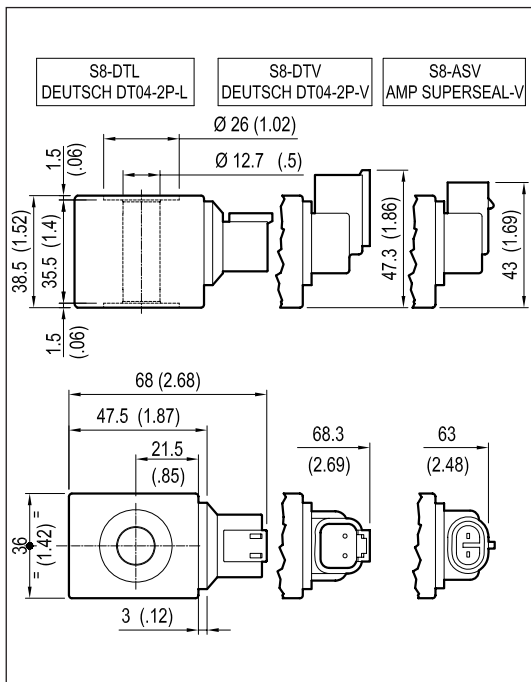

X	Y	Connections	Circuit	Voltage
20	30	DEUTSCH DT04-2P-L	Standard	DC only
20	3P	DEUTSCH DT04-2P-V	Standard	DC only
30	3P	AMP SUPERSEAL-V	Standard	DC only
22	30	DEUTSCH DT04-2P-L	Bidirectional Diode	DC only
22	3P	DEUTSCH DT04-2P-V	Bidirectional Diode	DC only
32	3P	AMP SUPERSEAL-V	Bidirectional Diode	DC only

Z	Voltage V	Resistance Ohm (±7%)	Power W	Current A		T °C (°F)
	Nominal	Ta = 20-25°C (68-77°F)	Cold coil	Cold coil	Hot coil	1 hour energized at Ta=20-25°C (68-77°F) Nominal voltage
OB	12 DC	7.4	20	1.62	1.19	105-110 (221-230)
OC	24 DC	28.5	20	0.85	0.61	
AC	26 DC	34.3	20	0.76	0.54	

Protection IP69 - DIN 40050 part 9
These coils have passed the THERMAL SHOCK DUNK TEST

SPARE PARTS

SOLENOID CARTRIDGE	
Port size	Ordering code
0M.43.20.80.03.20	OD.15.02.18.1A.S0.000
0M.43.20.80.03.35	
0M.43.20.80.04.20	
0M.43.20.80.04.35	
0M.43.20.80.05.20	OD.13.20.67.39.00.000
0M.43.20.80.05.35	
0M.43.20.80.06.20	
0M.43.20.80.06.35	

RELIEF CARTRIDGE	
Port size	Ordering code
0M.43.20.80.03.20	04.11.48.03.56.20
0M.43.20.80.04.20	
0M.43.20.80.05.20	
0M.43.20.80.06.20	
0M.43.20.80.03.35	04.11.48.03.56.35
0M.43.20.80.04.35	
0M.43.20.80.05.35	
0M.43.20.80.06.35	